

# Korniche Upstand

## Installation Guide



## TOOLS / PARTS REQUIRED



Cordless  
Screwdriver

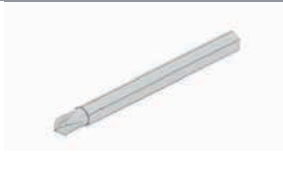

Crosshead Driver Bit



5mm x 100mm Screw  
(provided)



3.5mm x 45mm Screw  
(provided)



Spacer

## PACKAGING CONTENTS



**5mm x 100mm Screw**  
(provided)

USE ON FIXING POINTS  
MARKED IN RED



**3.5mm x 45mm Screw**  
(provided)

USE ON FIXING POINTS  
MARKED IN BLACK



Spacer X 1



Base Sections x 4



Upstand Widths x 2

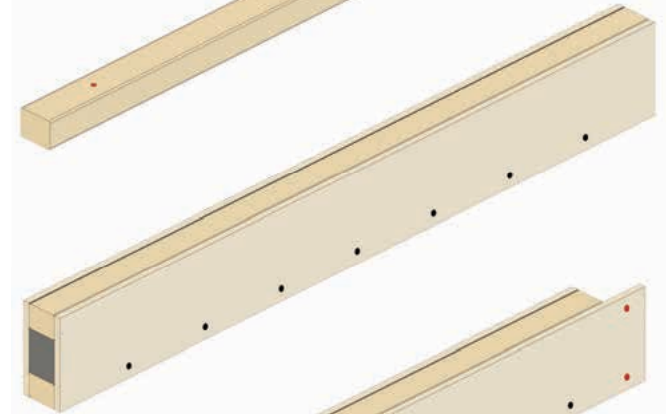

Upstand Lengths x 2

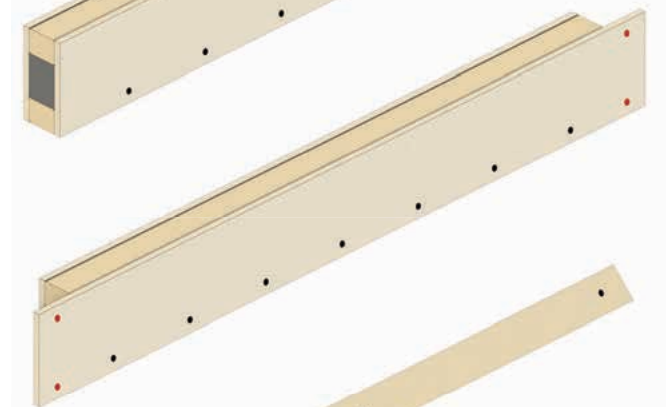

(Optional)  
Short Chamfered  
Batten x 2



(Optional)  
Long Chamfered  
Batten x 2

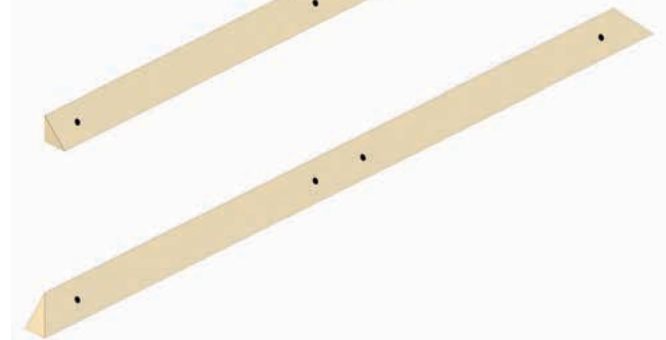

# FIT BOTTOM BASE RAILS

1

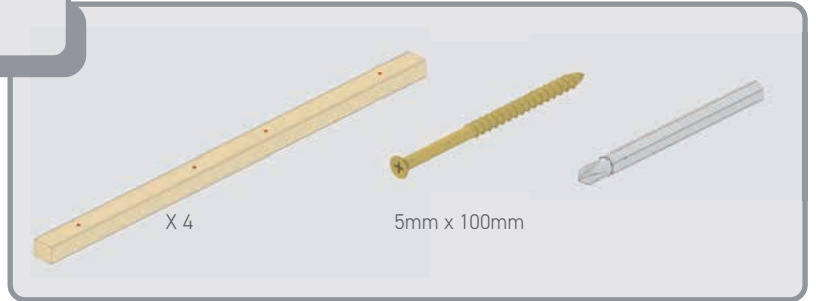

## Position bottom rail battens around structural opening

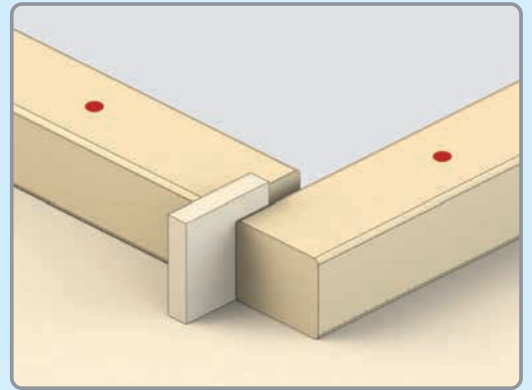
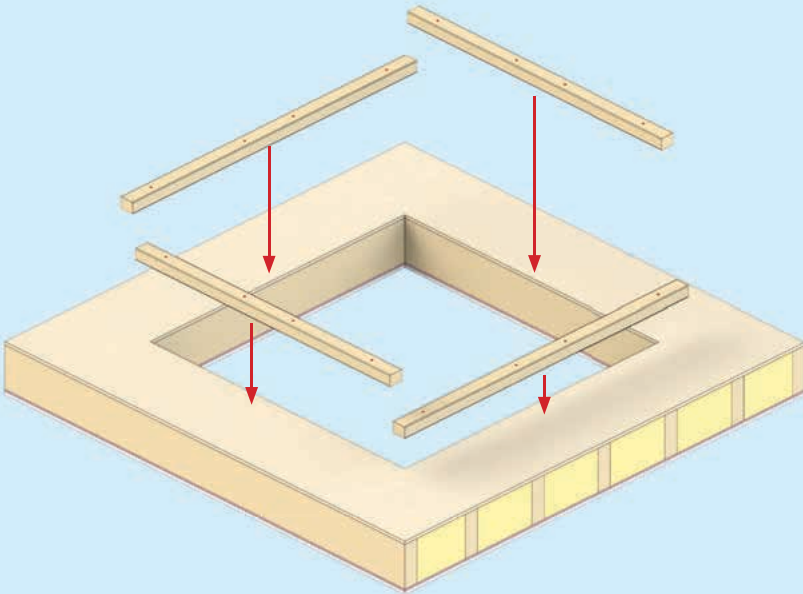

## Use Spacer to set to correct gaps

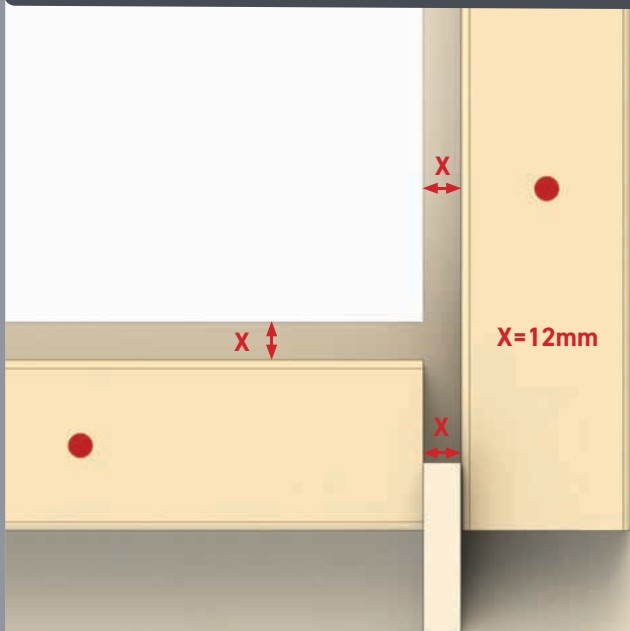

## Check diagonals

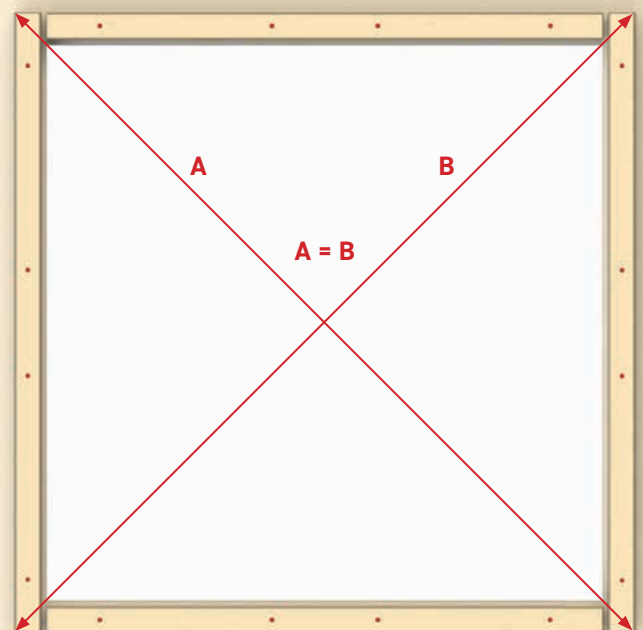

**5mm x 100mm Screw**  
(provided)



**USE ON FIXING POINTS  
MARKED IN RED**



centre

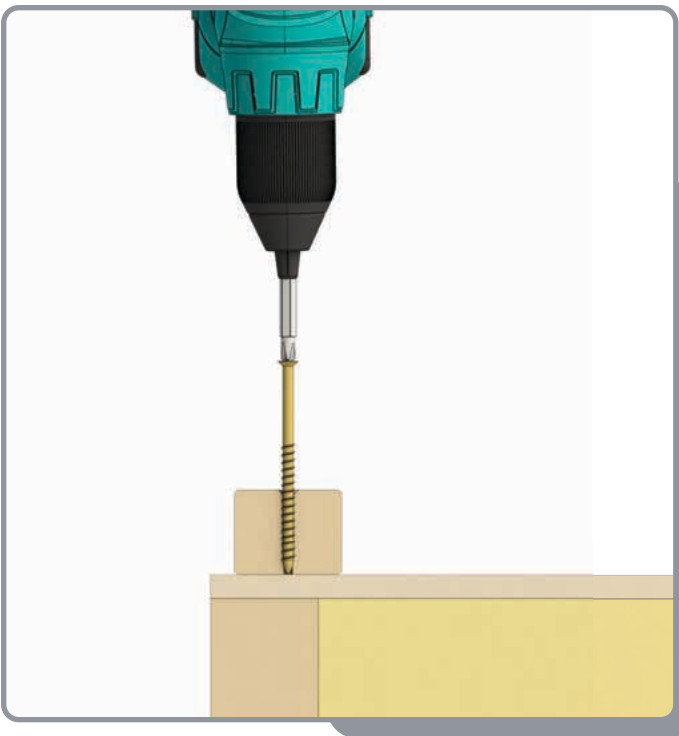
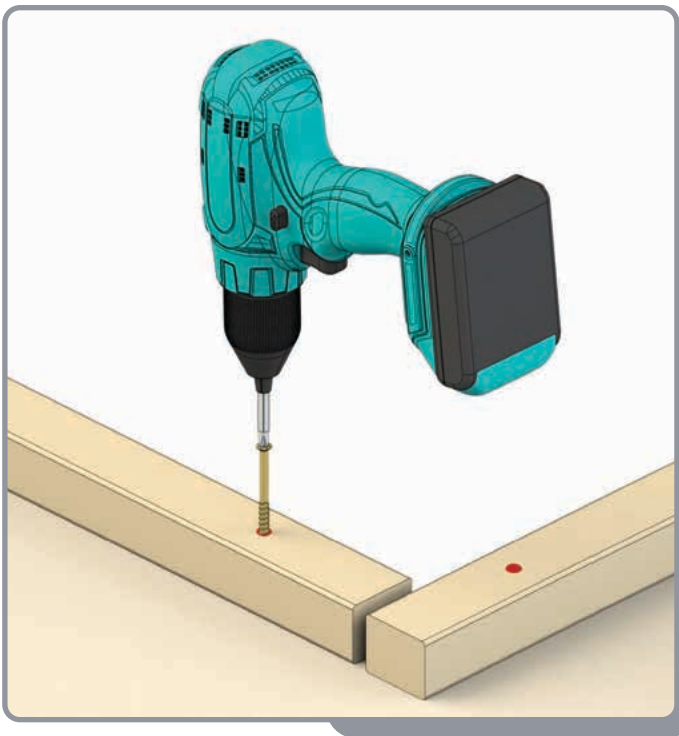
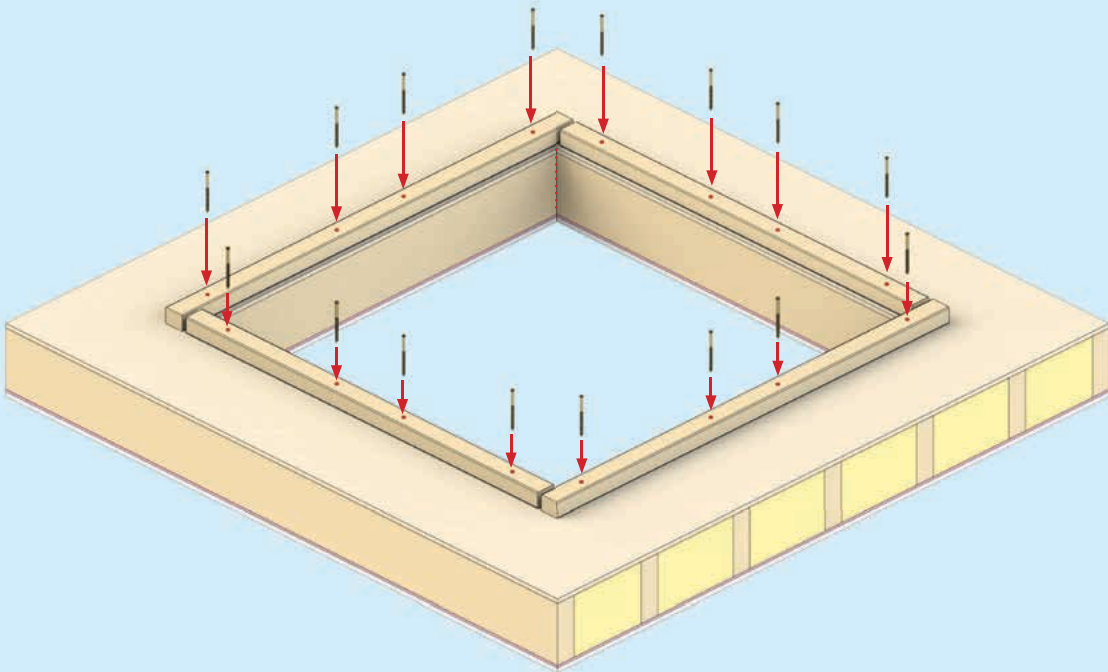

# FIT UPSTAND WIDTHS

2

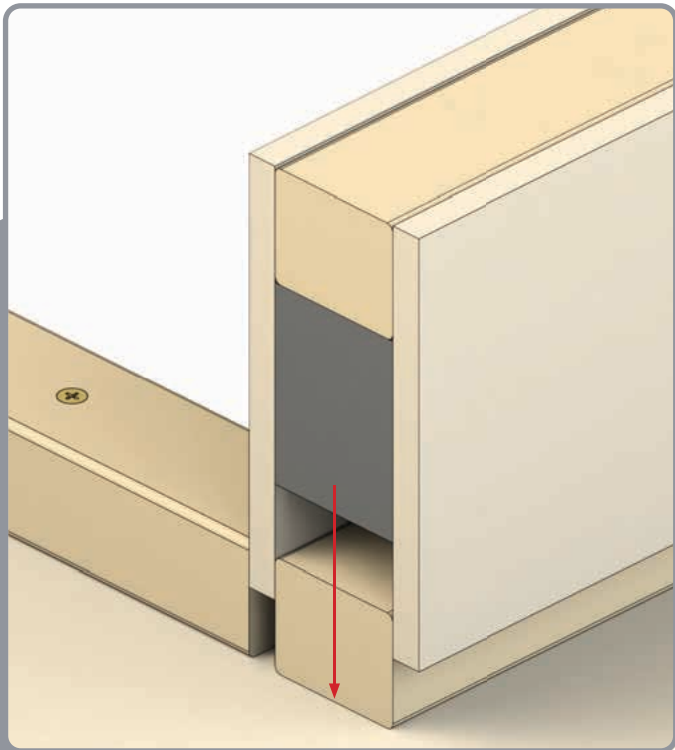
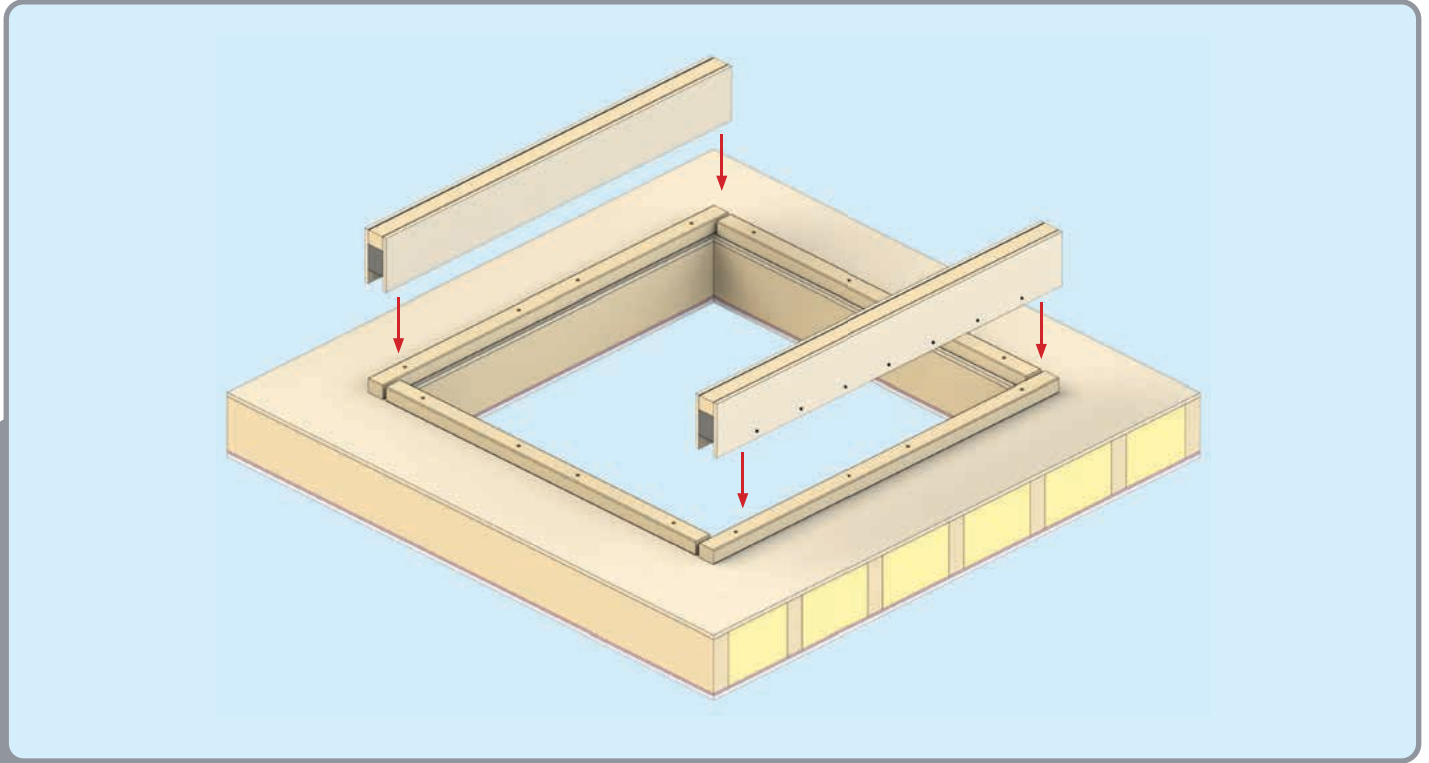
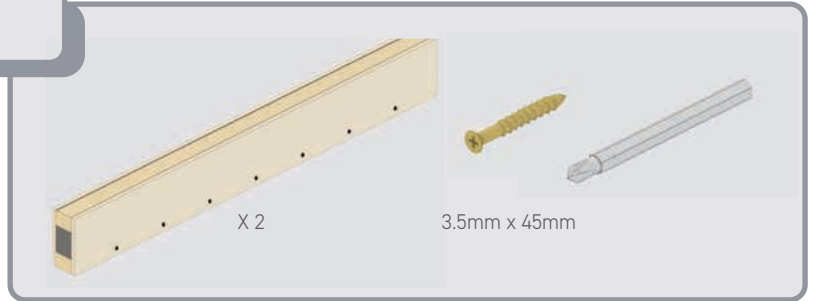

Ensure faces sit flush

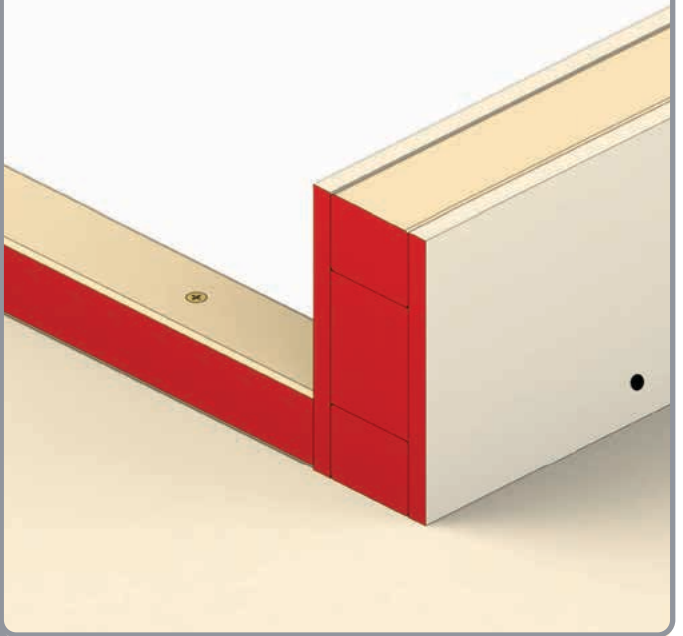



**3.5mm x 45mm Screw**  
(provided)

**USE ON FIXING POINTS  
MARKED IN BLACK**

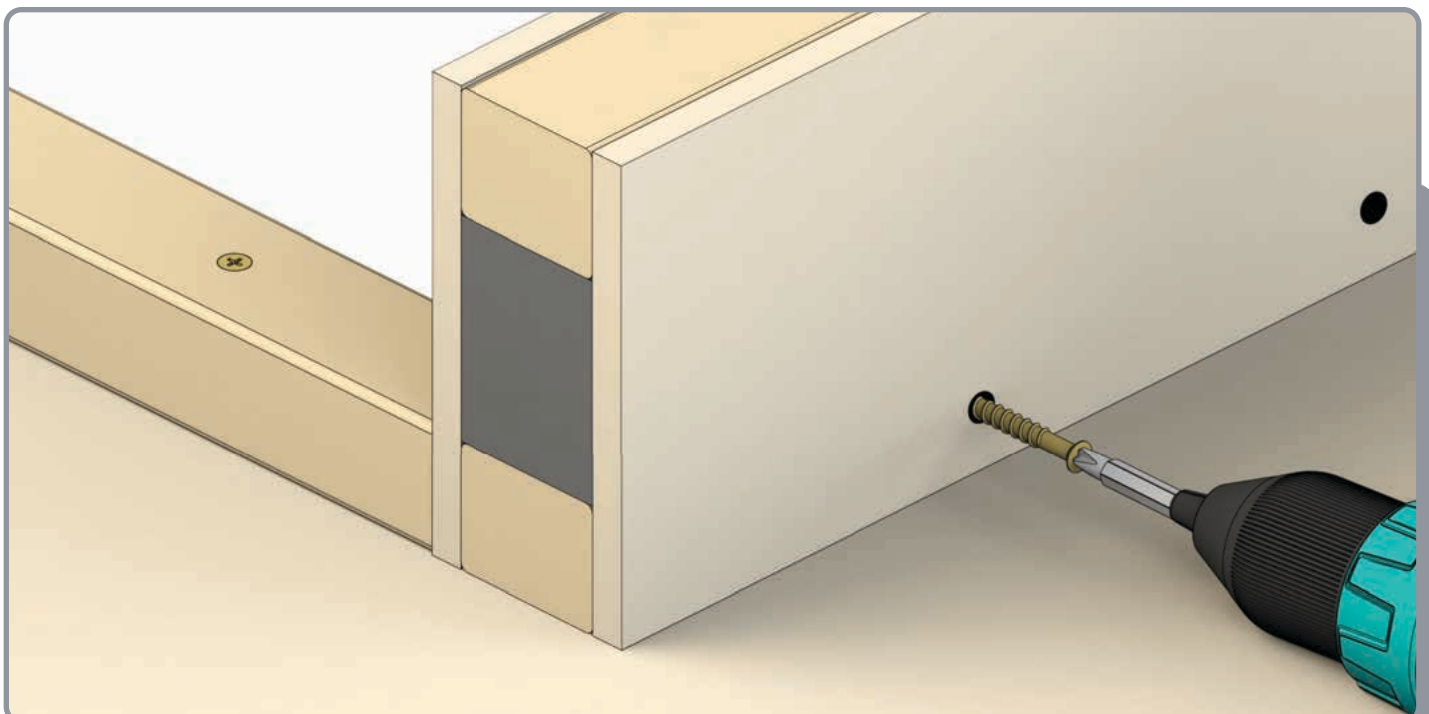
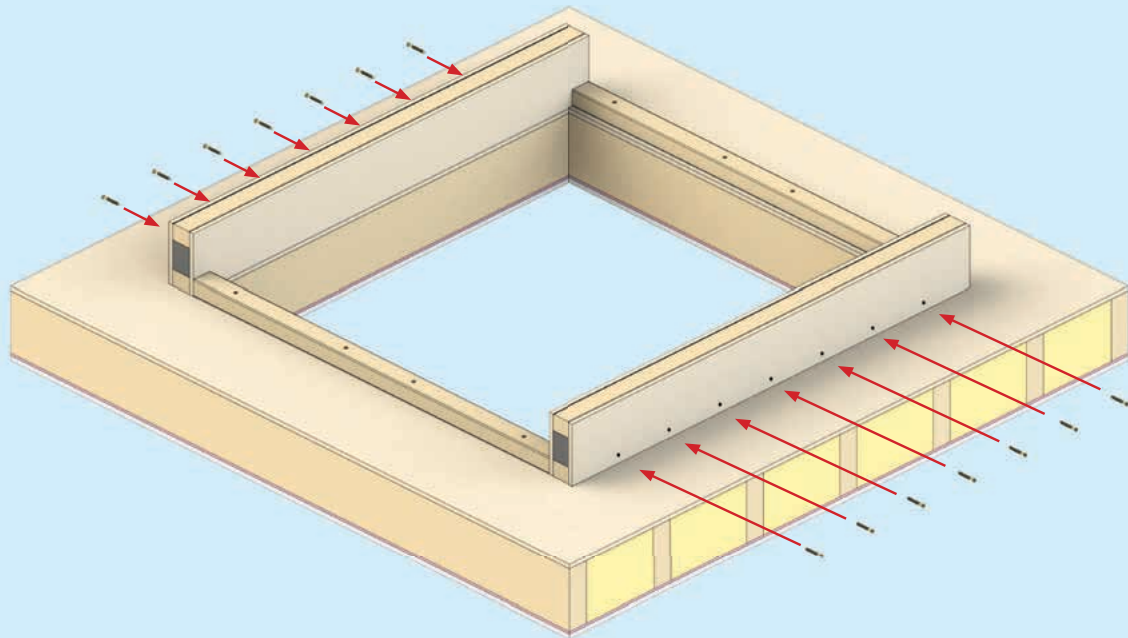
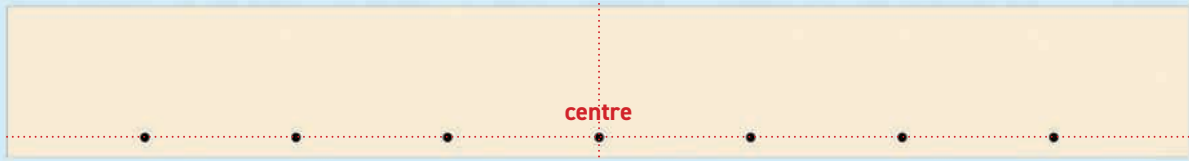

# FIT UPSTAND LENGTHS

3

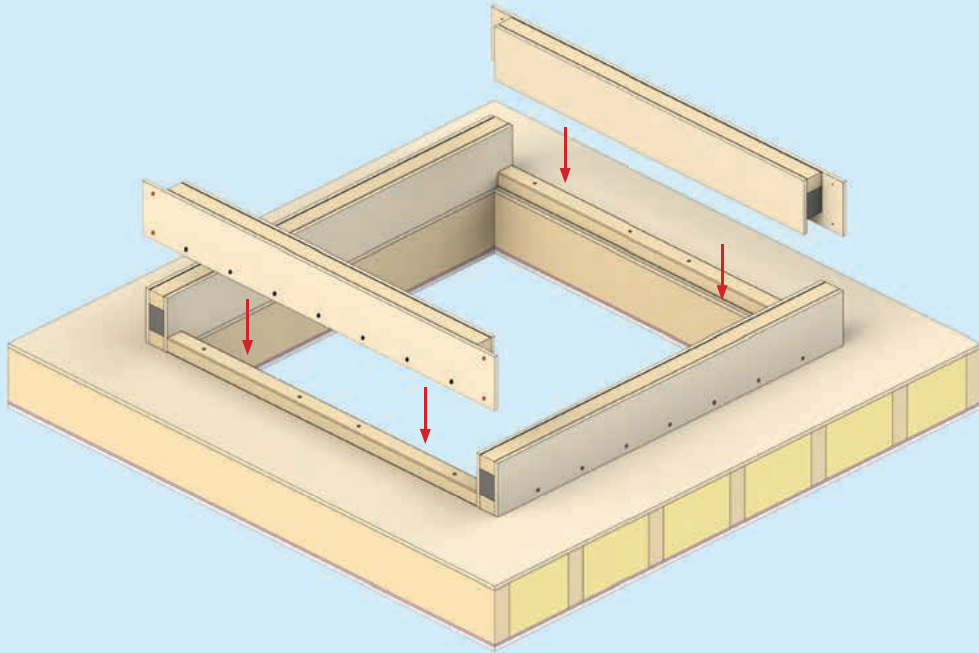
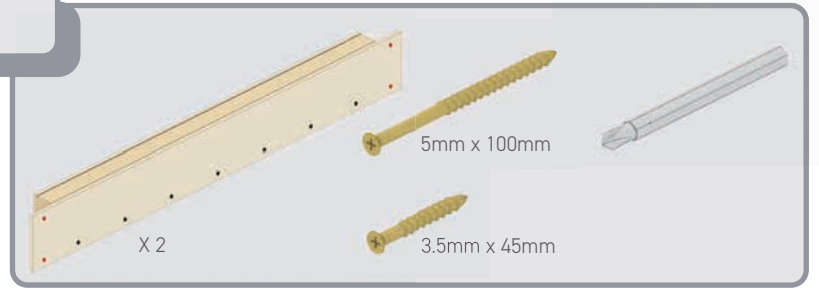

Ensure faces sit flush

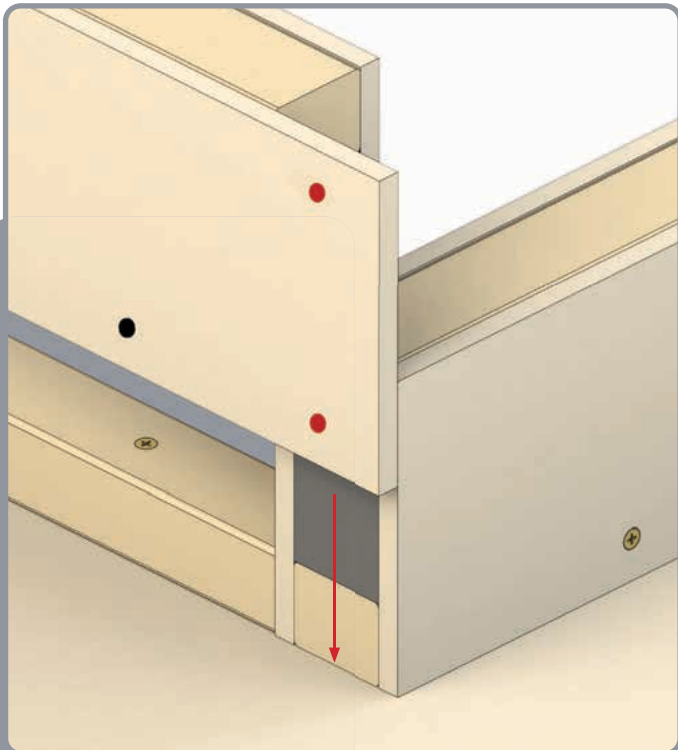



**3.5mm x 45mm Screw**  
(provided)

**USE ON FIXING POINTS  
MARKED IN BLACK**

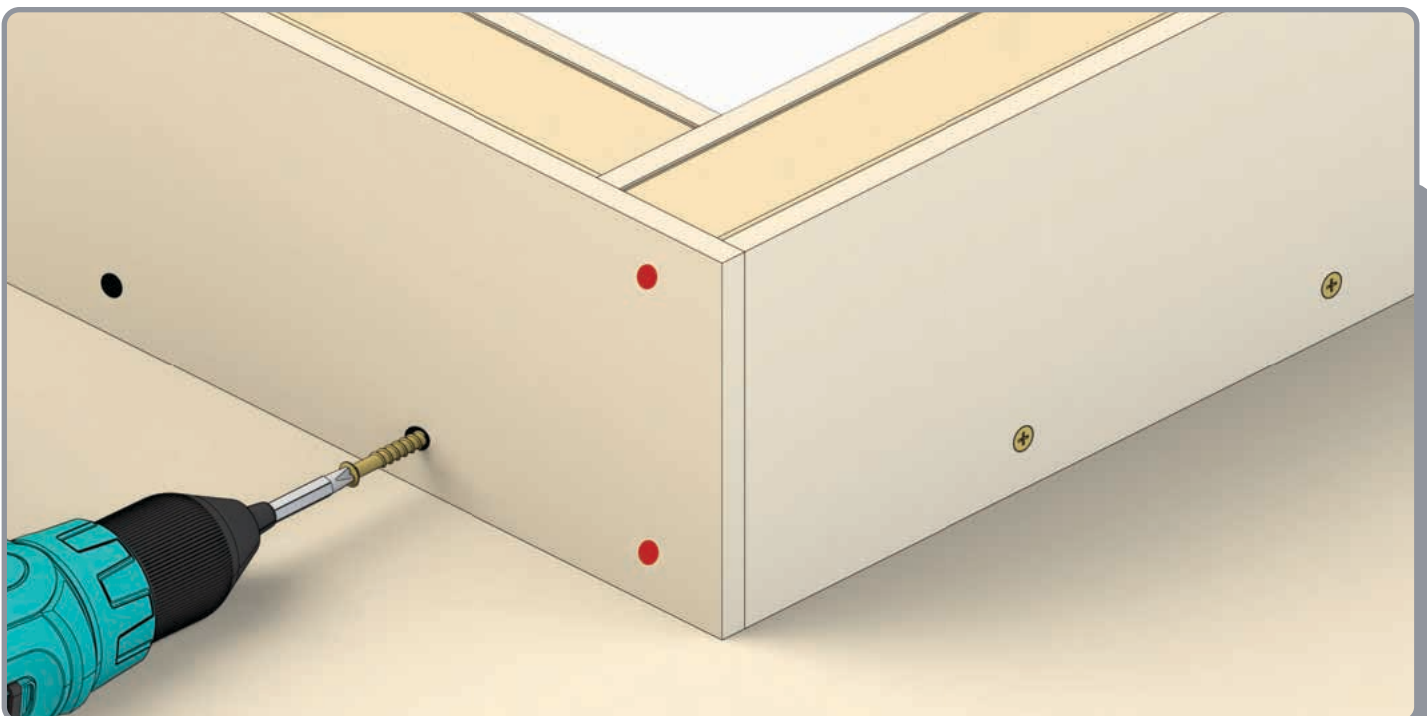
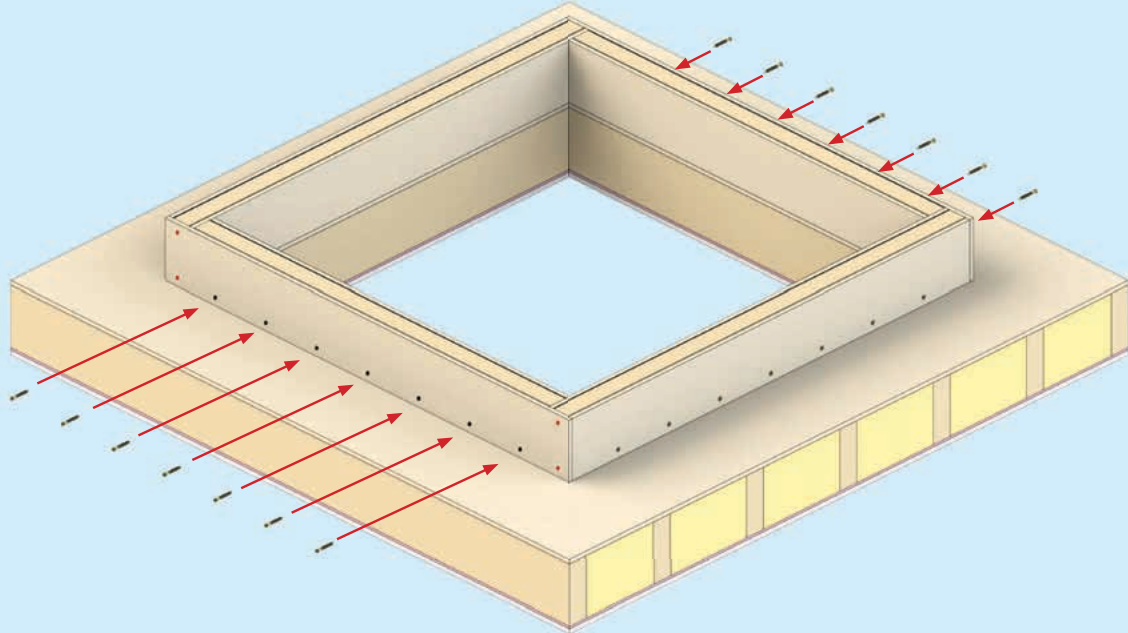



**5mm x 100mm Screw**  
(provided)

**USE ON FIXING POINTS  
MARKED IN RED**

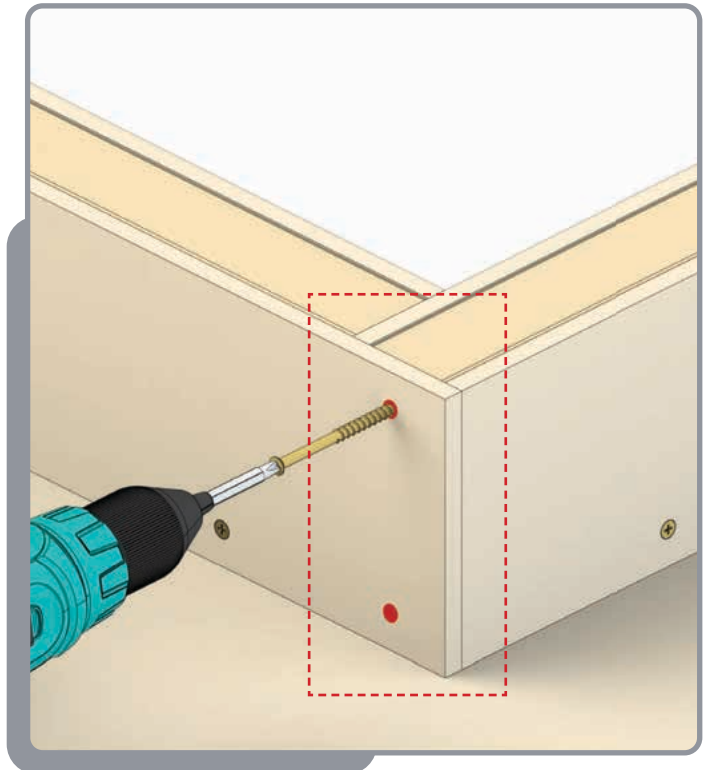
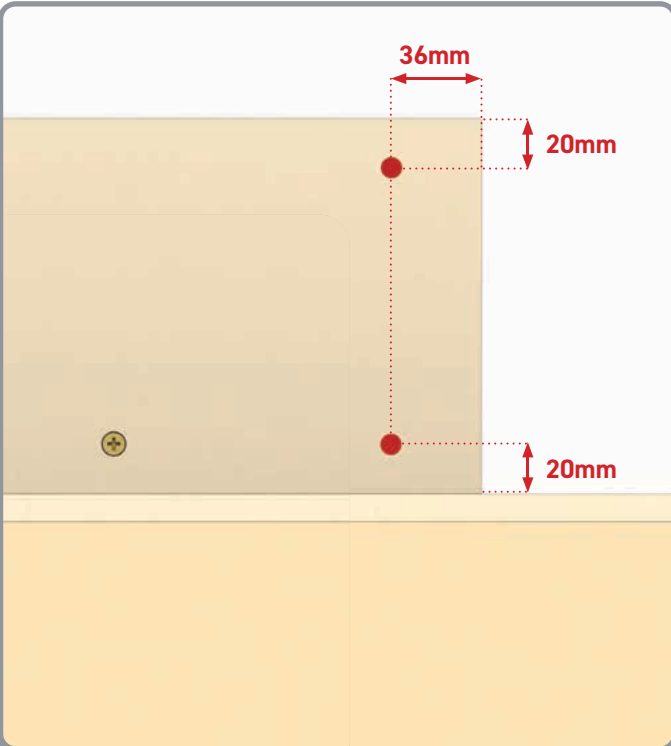
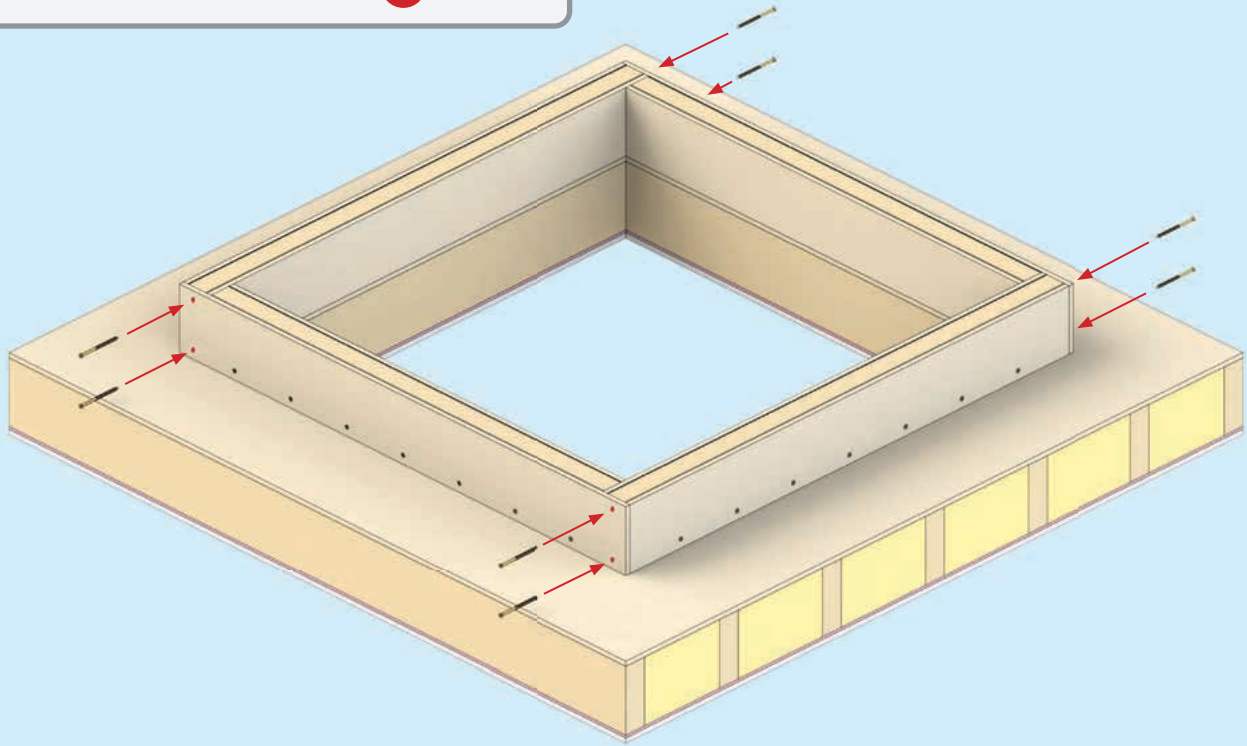

# OPTIONAL - FIT CHAMFERED BATTENS

4



## Position chamfered battens

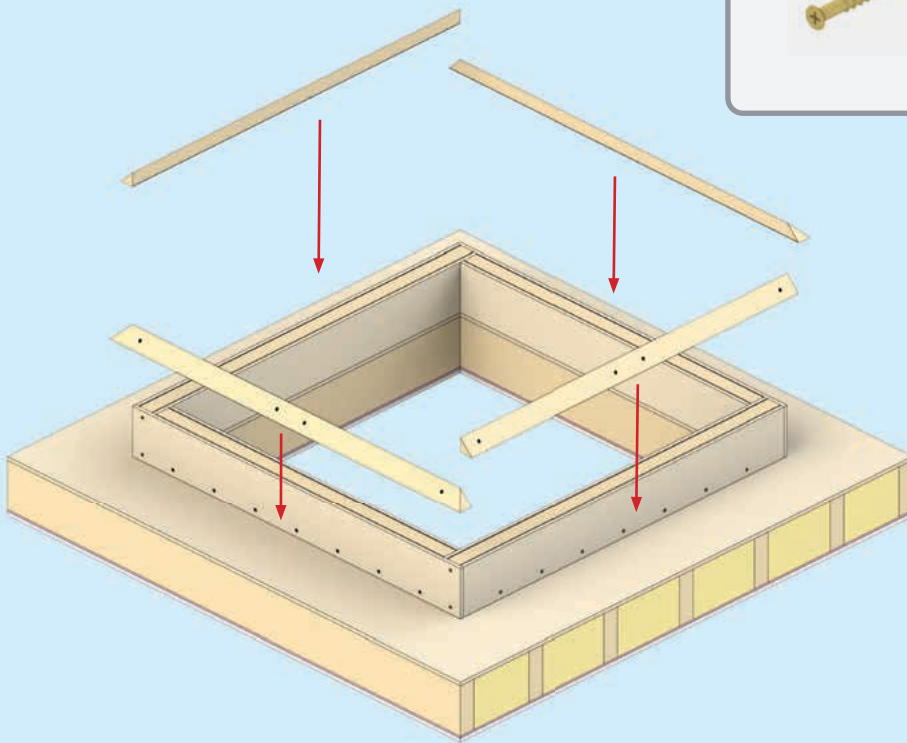

**3.5mm x 45mm Screw**  
(provided)

USE ON FIXING POINTS  
MARKED IN BLACK

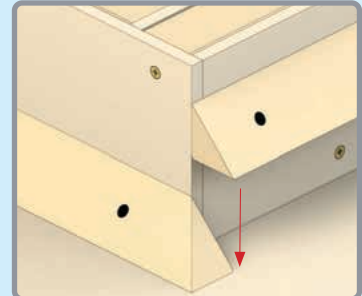

Ensure faces sit flush

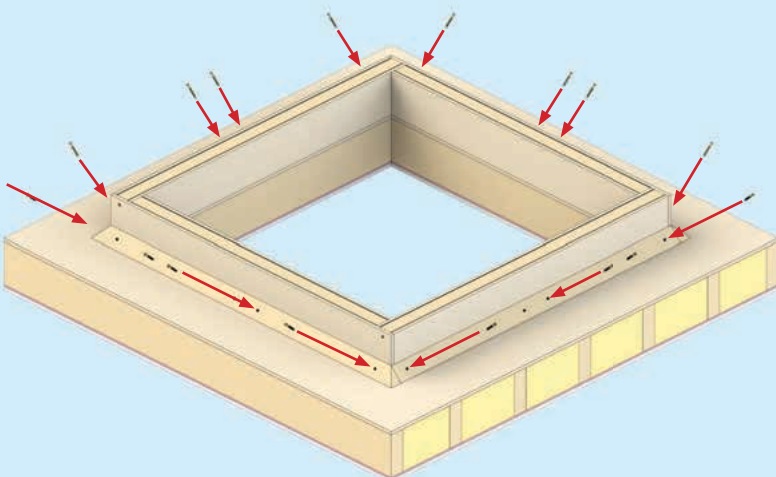
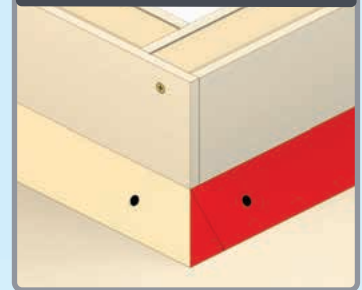



[www.korniche.co.uk](http://www.korniche.co.uk)